

## 不锈钢空心销轴链 Stainless steel hollow pin chains

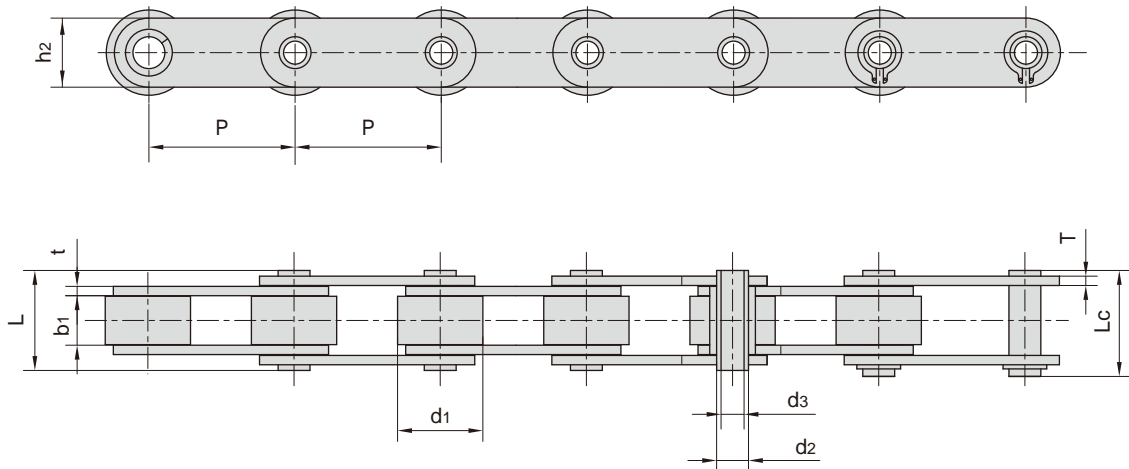

东华链号 Donghua Chain No.	节距	滚子直径	内节内宽	销轴直径		销轴长度		内链板高度	链板厚度	破断载荷	每米长重
	Pitch	Roller diameter	Width between inner plates	Pin diameter		Pin length		Inner plate depth	Plate thickness	Breaking load	Weight per meter
	P	d1 max	b1 min	d2 max	d3 min	L max	Lc max	h2 max	T max	Q min	q
	mm	mm	mm	mm	mm	mm	mm	mm	mm	kN/lbf	kg/m
C2042HPSS	25.400	15.88	7.85	5.63	4.00	16.50	17.60	12.00	1.50	7.7/1731	0.79
C2052HPSS	31.750	19.05	9.53	7.22	5.12	20.50	21.80	15.00	2.03	14.3/3215	1.27
C2062HPSS	38.100	22.23	12.70	8.31	6.00	25.80	26.80	17.00	2.42	16.8/3777	1.74
C2082HPSS	50.800	28.58	15.75	11.40	8.05	32.40	33.80	24.00	3.25	35.0/7868	2.86
C2042H-HPSS	25.400	15.88	7.85	5.63	4.00	18.80	19.90	12.00	2.03	7.7/1731	0.96
C2052H-HPSS	31.750	19.05	9.53	7.22	5.12	22.10	23.40	15.00	2.42	14.3/3215	1.46
C2062H-HPSS	38.100	22.23	12.70	8.31	6.00	29.20	30.20	17.00	3.25	16.8/3777	2.02
C2082H-HPSS	50.800	28.58	15.75	11.40	8.05	36.20	37.60	24.00	4.00	35.0/7868	3.30
HB25.4F2SS	25.400	15.89	17.26	9.00	6.35	31.30	32.50	20.00	2.50	24.0/5395	1.99
HB30SS	30.000	20.00	14.70	9.00	6.30	29.00	31.00	20.00	2.50	18.0/4046	2.23
HB45SS	45.000	28.00	17.75	10.00	6.00	34.50	36.60	25.40	3.00	35.0/7868	3.60
HB50F3SS	50.000	25.00	11.50	9.00	6.00	25.00	26.50	20.00	2.50	21.0/4721	1.24
HB50F5SS	50.000	28.00	17.75	10.00	6.00	34.50	36.60	25.00	3.00	35.0/7868	3.43
HB50F6SS	50.000	20.00	17.75	10.00	6.00	34.50	36.60	25.00	3.00	35.0/7868	2.51
C10HBSS	15.875	10.16	9.65	5.94	4.04	19.30	20.50	14.70	1.70	10.0/2248	0.99
C60HBF4SS	19.080	11.91	12.70	7.00	4.00	25.50	36.60	18.00	2.42	15.0/3372	1.70
MC35SS-P-50	50.000	31.00	14.80	14.00	10.20	31.00	33.00	25.00	3.00	21.0/4721	2.90
DH4203HPSS	76.200	31.75	15.00	14.00	10.10	25.00	39.00	26.00	3.80	29.4/6609	3.05