

S型钢制农机链 S type steel agricultural chains

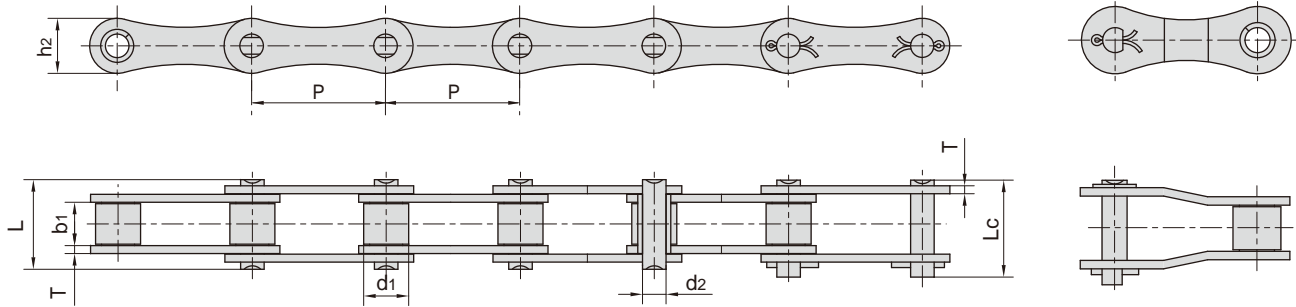

东华链号 Donghua Chain No.	节距	滚子直径	内节内宽	销轴直径	销轴长度		内链板高度	链板厚度	抗拉强度	平均抗拉强度	每米长重
	Pitch	Roller diameter	Width between inner plates	Pin diameter	L	Lc	Inner plate depth	Plate thickness	Tensile strength	Average tensile strength	Weight per meter
	P	d1 max	b1 min	d2 max	L max	Lc max	h2 max	t/T max	Q min	Q0	q
	mm	mm	mm	mm	mm	mm	mm	mm	kN/lbf	kN	kg/m
55V	41.40	17.90	22.23	8.22	39.3	42.4	20.0	3.0	42.00/9546	45.0	2.22
55VF1	41.40	17.90	22.23	8.22	39.3	42.4	21.4	3.0	45.00/10227	73.1	2.32
S32	29.21	11.43	15.88	4.45	26.7	28.8	13.2	1.8	8.00/1818	21.6	0.86
S32V	29.21	11.43	15.88	5.08	27.3	29.7	13.5	2.1	25.00/5680	27.0	0.96
S42	34.93	14.27	19.05	7.00	34.3	37.0	19.8	2.8	27.00/6136	50.8	1.60
S42F2	34.93	14.27	19.05	7.00	34.3	37.0	19.8	2.5/3.0	27.00/6136	50.8	1.82
S45	41.40	15.24	22.23	5.72	37.7	40.4	17.3	2.8	18.00/4091	36.1	1.66
S45H	41.40	15.24	22.23	7.14	39.5	42.5	17.3	3.0	37.65/8465	41.4	2.10
S51	38.10	15.24	16.00	5.72	30.9	33.8	17.3	2.8	28.00/6364	30.8	1.48
S52	38.10	15.24	22.23	5.72	37.7	40.4	17.3	2.8	18.00/4091	36.1	1.68
S52F10	38.10	14.00	22.00	6.92	36.5	39.1	18.2	2.5	23.50/5283	28.2	1.60
S52L	38.10	15.24	16.40	5.72	30.9	33.8	16.5	2.5	29.20/6636	32.2	1.36
S52LV	38.10	15.88	17.80	6.94	33.8	37.0	16.7	3.0	30.00/6818	32.5	1.58
S55	41.40	17.78	22.23	5.72	37.7	40.4	17.3	2.8	18.00/4091	36.1	1.80
S55R	41.40	17.78	22.23	8.90	41.0	44.0	22.4	3.5	45.00/10227	73.1	2.49
S55RH	41.40	17.78	22.23	8.90	43.2	46.4	22.4	4.0	65.00/14772	84.5	2.74
S55RHF1	41.40	25.00	22.23	8.90	43.2	46.4	22.4	4.0	65.00/14772	84.5	2.74
S62	41.91	19.05	26.20	5.72	40.3	43.0	17.3	2.5	26.70/6067	36.1	1.87
S62F10	41.91	19.05	25.40	5.72	39.4	42.2	17.3	2.5	26.70/6067	36.1	2.04
S62F5	41.91	19.05	26.20	5.72	40.3	43.0	16.7	2.5	26.70/6067	36.1	2.07
S62F8	41.91	19.05	27.90	10.00	44.9	49.3	25.0	3.0	45.00/10227	60.0	2.96
S62R	41.91	19.05	25.80	8.50	41.9	44.6	20.1	2.8	42.00/9546	45.0	2.43
S77	58.34	18.26	22.23	8.90	43.2	46.4	26.2	4.0	45.00/10227	73.1	2.66
S88	66.27	22.86	28.58	8.90	49.8	53.0	26.2	4.0	45.00/10227	73.1	3.25