

# 齿形链 Inverted tooth chains

## 外接触式齿形链 Flank contact silent chains

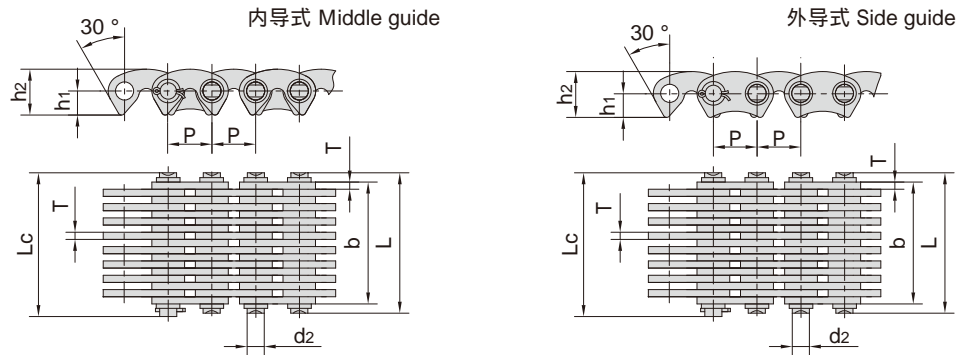

GB 链号 GB Chain No.	节距	链宽	销轴直径	销轴长度		孔中心到齿尖 距离	链板高度	链板厚度	导向型式	片数	抗拉强度	平均抗拉强度	每米长重
	Pitch	Chain width	Pin diameter	L max	Lc max	Distance from hole center to tooth	Plate depth	Plate thickness		Number of plates	Tensile strength	Average tensile strength	Weight per meter
	P mm	b min mm	d2 max mm	L max mm	Lc max mm	h1 mm	h2 max mm	T max mm		n	Q min kN/lbf	Q0 kN	q kg/m
SC3	9.525	10.5	3.95	15.8	17.5	5.3	10.0	1.5	外(Outside)	7	8.0/1798	8.9	0.48
		13.5		18.5	20.0				外(Outside)	9	10.0/2272	11.2	0.60
		16.5		21.5	23.0				外(Outside)	11	12.5/2840	14.0	0.73
		19.5		24.5	26.0				外(Outside)	13	15.0/3409	16.8	0.85
		22.5		27.5	29.0				外(Outside)	15	17.5/3997	19.6	1.00
		28.5		33.5	35.0				内(Inside)	19	22.5/5114	25.2	1.26
		34.5		39.5	41.5				内(Inside)	23	27.5/6182	30.8	1.60
		37.5		42.5	44.0				内(Inside)	25	30.0/6744	33.6	1.73
		40.5		45.5	47.5				内(Inside)	27	32.5/7306	36.4	1.86
		43.5		48.5	50.2				内(Inside)	29	35.0/7868	39.2	1.99
SC4	12.700	19.5	5.08	24.5	26.0	7.0	13.5	1.5	外(Outside)	13	23.4/5318	26.2	1.15
		22.5		27.5	29.0				外(Outside)	15	27.4/6227	30.6	1.33
		25.5		30.5	32.0				外(Outside)	17	31.3/7114	35.0	1.50
		28.5		33.5	35.0				内(Inside)	19	35.2/8000	39.4	1.68
		34.5		39.5	41.0				内(Inside)	23	43.0/9772	48.1	2.04
		40.5		45.5	47.0				内(Inside)	27	50.8/11364	56.8	2.39
		46.5		51.5	53.0				内(Inside)	31	58.6/13318	65.6	2.74
		52.5		57.5	59.0				内(Inside)	35	66.4/15091	74.3	3.10
SC5	15.875	22.0	5.92	29.0	30.2	8.7	16.7	2.0	内(Inside)	11	32.6/7328	36.1	1.62
		26.0		33.0	34.2				内(Inside)	13	39.0/8767	43.2	1.92
		30.0		37.0	38.2				内(Inside)	15	45.6/10364	50.6	2.21
		34.0		41.0	42.2				内(Inside)	17	52.1/11712	57.8	2.51
		38.0		45.0	46.2				内(Inside)	19	58.6/13318	65.0	2.80
		42.0		49.0	50.3				内(Inside)	21	65.1/14634	72.2	3.10
		46.0		53.0	54.2				内(Inside)	23	71.7/16295	79.5	3.39
		50.0		57.0	58.4				内(Inside)	25	75.0/16860	83.2	3.69
		54.0		61.0	62.4				内(Inside)	27	84.7/19250	94.0	3.99
		62.0		69.0	70.4				内(Inside)	31	97.7/22204	108.4	4.58
		66.0		73.0	74.4				内(Inside)	33	100.0/22480	111.0	4.88
		70.0		77.0	78.4				内(Inside)	35	111.0/24953	123.2	5.18
78.0	85.0	86.4	内(Inside)	39	124.0/27875	137.6	5.77						

# 齿形链 Inverted tooth chains

## 外接触式齿形链 Flank contact silent chains

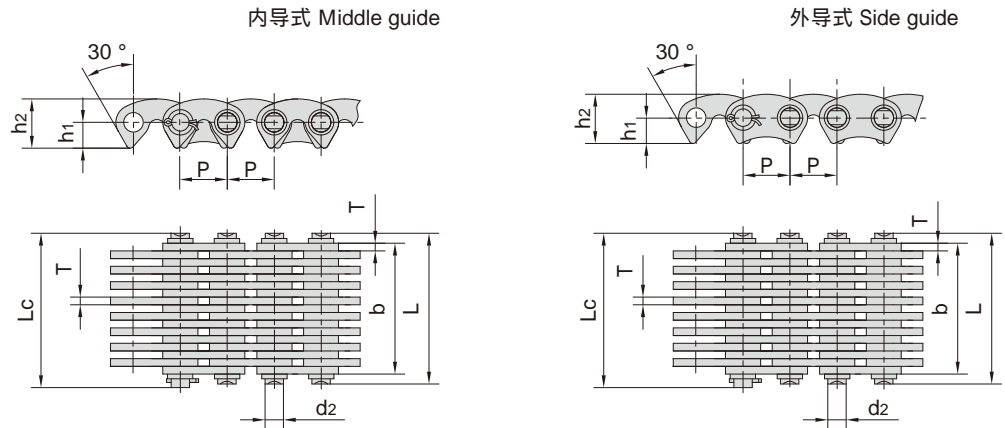

GB 链号 GB Chain No.	节距	链宽	销轴直径	销轴长度		孔中心到齿尖 距离 Distance from hole center to tooth h1	链板高度 Plate depth h2	链板厚度 Plate thickness T	导向型式 Guide type	片数 Number of plates n	抗拉强度 Tensile strength Q min kN/lbf	平均抗拉强度 Average tensile strength Q0 kN	每米长重 Weight per meter q kg/m
	Pitch	Chain width b	Pin diameter d2	L	Lc								
	mm	min mm	max mm	max mm	max mm								
SC6	19.050	26.0	6.90	33.0	34.8	8.7	16.7	2.0	内(Inside)	13	46.0/10341	51.0	2.46
		34.0		41.0	42.5				内(Inside)	17	62.5/14050	69.3	3.16
		38.0		45.0	46.5				内(Inside)	19	70.0/15909	77.6	3.37
		46.0		53.0	54.5				内(Inside)	23	86.0/19545	95.4	4.08
		50.0		57.8	59.6				内(Inside)	25	93.7/21064	104.0	4.59
		54.0		61.0	62.8				内(Inside)	27	102.0/23182	113.2	4.78
		58.0		65.8	67.6				内(Inside)	29	108.8/24458	120.7	5.30
		62.0		69.0	70.8				内(Inside)	31	117.0/26591	129.8	5.50
		66.0		73.8	75.6				内(Inside)	33	124.4/27965	138.0	6.01
		70.0		77.0	78.8				内(Inside)	35	133.0/30227	147.6	6.20
		74.0		82.5	84.5				内(Inside)	37	140.6/31607	156.0	6.83
		78.0		85.0	86.8				内(Inside)	39	149.0/33495	165.3	7.07
		86.0		93.0	94.8				内(Inside)	43	164.0/36867	182.0	7.79
		94.0		101.0	102.8				内(Inside)	47	180.0/40464	199.8	8.50
		126.0		133.0	135.0				内(Inside)	63	191.4/43027	212.4	11.38
158.0	165.0	166.8	内(Inside)	79	240.0/53952	266.4	14.19						
SC8	25.400	27.0	8.90	34.0	36.0	10.5	20.0	2.0	内(Inside)	9	70.0/15736	77.7	3.36
		33.0		40.5	42.0				内(Inside)	11	78.1/17557	86.6	4.07
		45.0		52.0	53.5				内(Inside)	15	111.0/25227	123.2	5.31
		51.0		58.0	59.5				内(Inside)	17	125.0/28409	138.7	6.02
		57.0		64.0	65.5				内(Inside)	19	141.0/32045	156.5	6.37
		69.0		76.2	77.7				内(Inside)	23	172.0/39091	190.9	8.15
		81.0		88.2	89.7				内(Inside)	27	203.0/46163	225.3	9.57
		93.0		100.2	101.7				内(Inside)	31	235.0/53409	260.8	10.98

# 齿形链 Inverted tooth chains

## 外接触式齿形链 Flank contact silent chains

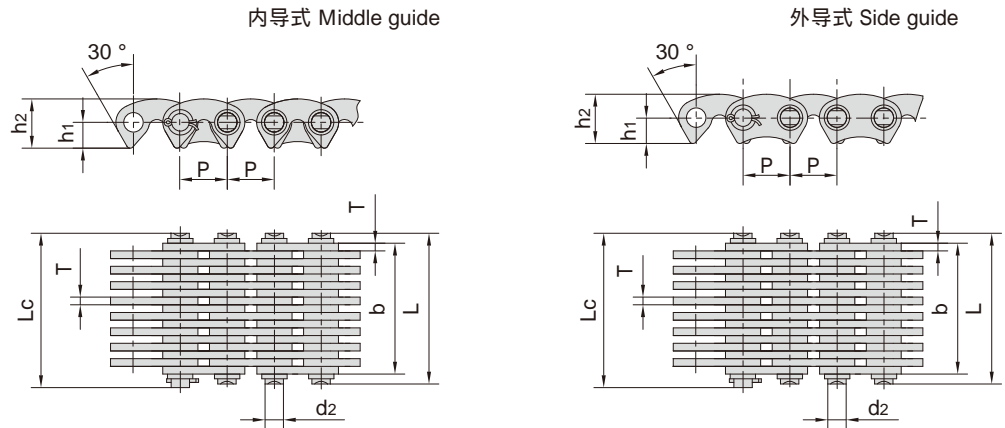

GB 链号 GB Chain No.	节距	链宽	销轴直径	销轴长度		孔中心到齿尖 距离	链板高度	链板厚度	导向型式	片数	抗拉强度	平均抗拉强度	每米长重
	Pitch	Chain width	Pin diameter	L max	Lc max	Distance from hole center to tooth	Plate depth	Plate thickness		Number of plates	Tensile strength	Average tensile strength	Weight per meter
	P mm	b min mm	d2 max mm	L max mm	Lc max mm	h1 mm	h2 max mm	T max mm			Q min kN/lbf	Q0 kN	
SC10	31.750	10.84	17.5	33.4	3.0	内(Inside)	19	165.0/37500	183.1	8.42			
							21	156.0/35069	173.1	7.57			
							23	201.0/45681	223.1	10.19			
							25	187.5/42150	208.1	8.97			
							27	203.0/46163	225.3	9.57			
							29	219.0/49231	243.0	10.38			
							31	273.0/62045	303.0	13.73			
							33	245.0/55076	271.9	11.79			
							35	310.0/70454	341.0	15.50			
							35	266.0/59797	295.2	12.49			
							37	274.0/61595	304.1	13.21			
							39	346.0/78636	380.6	12.27			
							39	297.0/66766	329.6	13.87			
							45	334.0/75083	370.7	16.00			
*SC8F1	25.400	8.90	14.0	26.7	2.0	内(Inside)	15	74.0/16635	81.4	3.74			
							17	84.0/18883	92.4	4.22			
							19	94.0/21131	103.4	4.69			
							23	115.0/25852	126.5	5.64			
							27	136.0/30573	149.6	6.59			
							31	157.0/35294	172.7	7.54			
							35	178.0/40014	195.8	8.49			
							39	198.0/44510	217.8	9.44			

\*表示东华链号  
\*Indicate Donghua chain No.

# 齿形链 Inverted tooth chains

## 内接触式齿形链 Crotch contact silent chains

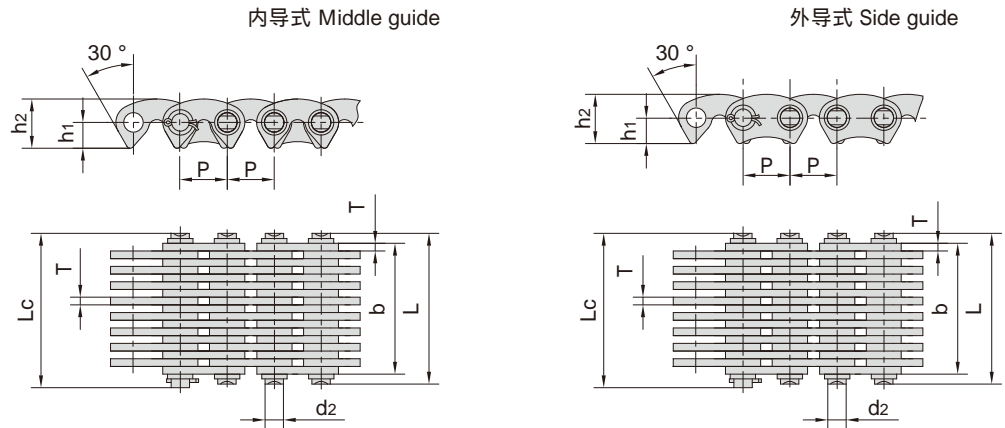

东华链号 Donghua Chain No.	节距	链宽	销轴直径	销轴长度		孔中心到齿尖 距离	链板高度	链板厚度	导向型式	片数	抗拉强度	平均抗拉强度	每米长重
	Pitch	Chain width	Pin diameter	Pin length		Distance from hole center to tooth	Plate depth	Plate thickness	Guide type	Number of plates	Tensile strength	Average tensile strength	Weight per meter
	P mm	b min mm	d2 max mm	L max mm	Lc max mm	h1 mm	h2 max mm	T max mm		n	Q min kN/lbf	Q0 kN	q kg/m
C4-120	12.7	19.5	5.08	24.5	26.0	6.62	12.1	1.5	内(Inside)	13	20.0/4545	22.2	1.20
C4-123		22.5		27.5	29.0				内(Inside)	15	23.0/5227	25.5	1.37
C4-129		28.5		33.5	35.0				内(Inside)	19	28.5/6477	31.6	1.72
C4-132		31.5		36.5	38.0				内(Inside)	21	31.5/7159	34.9	1.89
C4-138		37.5		42.5	44.0				内(Inside)	25	38.0/8636	42.1	2.22
C4-150		49.5		54.5	56.0				内(Inside)	33	50.0/11363	55.5	2.90
C4-320	12.7	19.5	5.08	24.5	26.0	6.62	12.1	1.5	外(Outside)	13	20.0/4545	22.2	1.21
C4-323		22.5		27.5	29.0				外(Outside)	15	23.0/5227	25.5	1.38
C4-329		28.5		33.5	35.0				外(Outside)	19	28.5/6477	31.6	1.73
C4-332		31.5		36.5	38.0				外(Outside)	21	31.5/7159	34.9	1.90
C4-338		37.5		42.5	44.0				外(Outside)	25	38.0/8636	42.1	2.23

## 双节距齿形链 Double pitch silent chains

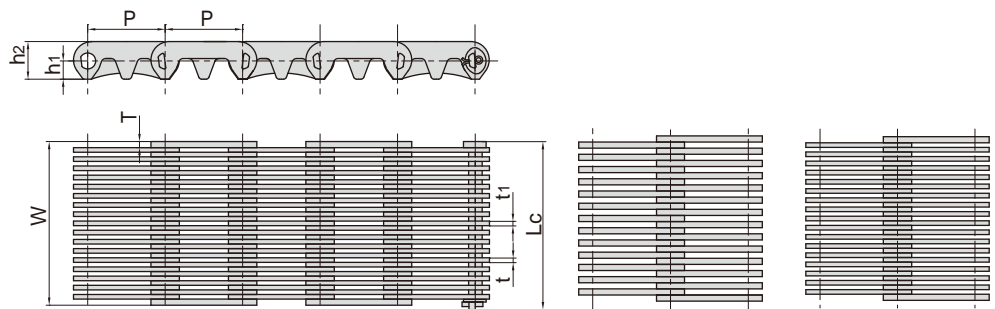

东华链号 Donghua Chain No.	节距	链宽	销轴长度	链板高度		内节内宽		导向型式	片数	抗拉强度	每米长重
	Pitch	Chain width	Pin length	Plate depth		Plate thickness		Guide type	Number of plates	Tensile strength	Weight per meter
	P mm	W min mm	Lc max mm	h1 mm	h2 mm	t/t1 max mm	T max mm		n	Q min kN/lbf	q kg/m
CL208F1-55.8N	25.4	55.8	55.8	6.2	12.6	2.0	1.5	内(Inside)	35(18X17)	66.4/14928	2.59
HV4TT-14X13N	25.4	55.8	55.8	6.2	12.6	2.0	2.0	内(Inside)	27(14X13)	66.4/14928	2.57