

摩托车链 Motorcycle chains

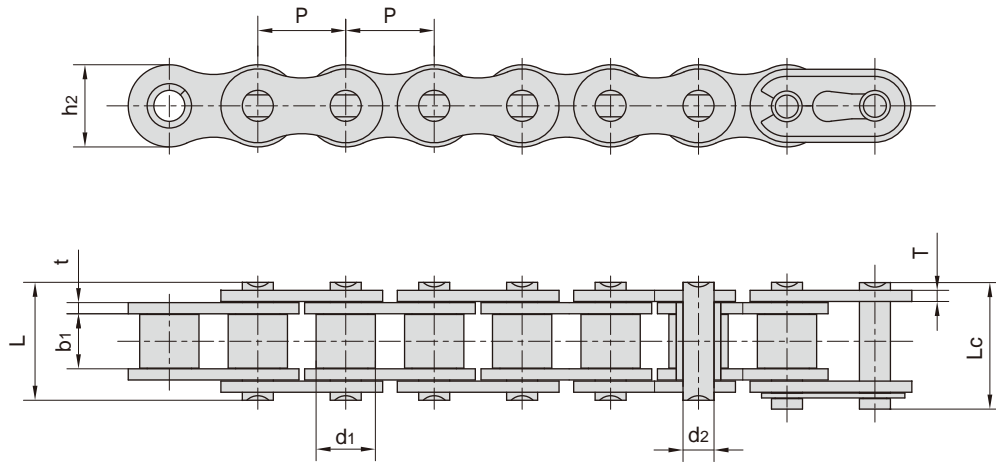

ISO链号 ISO Chain No.	东华链号 Donghua Chain No.	节距 Pitch	滚子直径 Roller diameter	内节内宽 Width between inner plates	销轴直径 Pin diameter	销轴长度 Pin length		内链板高度 Inner plate depth	链板厚度 Plate thickness	抗拉强度 Tensile strength	平均抗拉强度 Average tensile strength	每米长重 Weight per meter
		P	d1 max	b1 min	d2 max	L max	Lc max	h2 max	t/T max	Q min	Q0	q
		mm	mm	mm	mm	mm	mm	mm	mm	kN/lbf	kN	kg/m
-	*T3F	9.525	6.00	9.50	4.50	18.60	20.00	9.30	1.85/1.50	11.80/2653	13.6	0.61
420	420	12.700	7.77	6.25	3.96	14.70	16.10	12.00	1.50	16.00/3597	17.6	0.55
-	420F3	12.700	7.77	6.40	3.97	15.00	16.60	11.80	1.60/1.45	16.00/3597	17.6	0.64
-	420HF1	12.700	7.77	6.25	3.96	17.00	18.40	12.00	2.03	16.00/3597	17.6	0.76
-	420HT	12.700	7.77	6.25	3.96	17.00	-	12.00	2.03	21.40/4811	23.5	0.76
428	428	12.700	8.51	7.75	4.45	16.70	18.20	11.80	1.60	17.80/4002	19.6	0.70
-	428F1	12.700	8.51	7.94	4.50	16.70	18.05	11.80	1.60	17.15/3855	19.4	0.71
-	428DS	12.700	8.51	7.94	4.45	17.90	19.30	12.00	1.85	18.62/4186	21.0	0.76
428MH	428H	12.700	8.51	7.85	4.45	18.80	19.90	11.80	2.03	20.60/4631	23.4	0.79
-	428HF1	12.700	8.51	7.85	4.45	17.90	19.00	11.80	1.80	19.50/4384	20.7	0.74
-	428HSH	12.700	8.51	7.75	4.45	20.00	-	12.00	2.42	27.00/6070	29.4	0.89
-	428HF4	12.700	8.51	7.94	4.50	18.90	20.10	11.80	2.03	20.50/4609	23.4	0.82
-	428HD	12.700	8.51	7.85	4.45	18.80	19.90	11.80	2.03	20.60/4631	23.4	0.85
-	428F3	12.700	8.51	7.85	4.45	16.70	18.20	11.70	1.60	17.80/4002	19.6	0.77
-	428F4	12.700	8.51	7.85	4.45	16.70	18.20	11.80	1.60	17.80/4002	19.6	0.72

*套筒链:表中滚子直径d1为套筒直径.

*Bush chain:d1 in the table indicates the external diameter of the bush.

摩托车链 Motorcycle chains

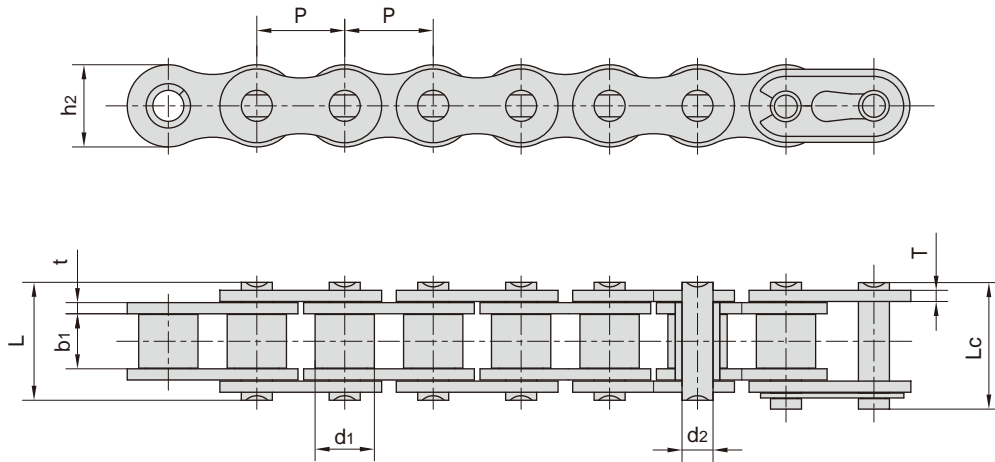

ISO链号 ISO Chain No.	东华链号 Donghua Chain No.	节距 Pitch	滚子直径 Roller diameter	内节内宽 Width between inner plates	销轴直径 Pin diameter	销轴长度 Pin length		内链板高度 Inner plate depth	链板厚度 Plate thickness	抗拉强度 Tensile strength	平均抗拉强度 Average tensile strength	每米长重 Weight per meter
		P	d_1 max	b_1 min	d_2 max	L max	L_c max	h_2 max	t/T max	Q min	Q_0	q
		mm	mm	mm	mm	mm	mm	mm	mm	kN/lbf	kN	kg/m
520	520	15.875	10.16	6.25	5.08	17.50	19.00	15.09	2.03	26.50/5957	29.7	0.89
-	520F2	15.875	10.16	6.35	5.24	17.50	19.05	15.09	2.03	26.50/5957	29.7	0.97
-	520F3	15.875	10.16	6.48	5.08	17.50	19.00	15.09	2.03	26.50/5957	29.7	0.89
520MH	520MH	15.875	10.22	6.25	5.25	19.00	21.20	15.30	2.20	30.50/6857	33.6	-
-	520HD	15.875	10.16	6.35	5.34	18.60	20.00	15.09	2.20	35.00/7868	38.5	1.04
525	525	15.875	10.16	7.95	5.08	19.30	20.70	15.09	2.03	26.50/5957	29.7	1.06
525MH	525MH	15.875	10.22	7.85	5.25	21.20	23.20	15.30	2.20	30.50/6857	33.6	-
-	525HF1	15.875	10.16	7.95	5.08	20.90	22.30	15.09	2.42	26.50/5957	29.7	1.20
530	530	15.875	10.16	9.40	5.08	20.70	22.20	15.09	2.03	26.50/5957	29.7	1.06
-	530SH	15.875	10.16	9.40	5.08	22.10	-	15.09	2.42	32.80/7374	33.5	1.24
-	520F12	15.875	10.16	6.25	5.25	17.60	-	15.00	2.03	29.43/6615	32.3	0.98
-	520HF7	15.875	10.22	7.80	5.30	21.35	-	15.30	2.8/2.42	40.00/8992	44.0	1.43
630	630	19.050	11.91	9.40	5.94	23.00	24.80	18.00	2.42	35.30/7936	38.8	-

O形密封圈摩托车链 O-Ring motorcycle chains

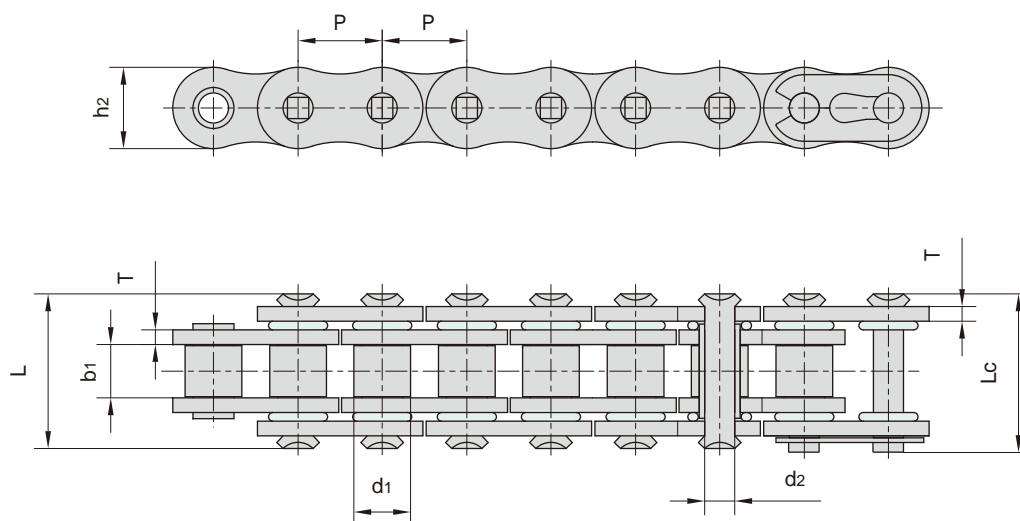

东华链号 Donghua Chain No.	节距	滚子直径	内节内宽	销轴直径	销轴长度		内链板高度	链板厚度	抗拉强度	平均抗拉强度	每米长重
	Pitch	Roller diameter	Width between inner plates	Pin diameter	Pin length		Inner plate depth	Plate thickness	Tensile strength	Average tensile strength	Weight per meter
	P	d1 max	b1 min	d2 max	L max	Lc max	h2 max	T max	Q min	Q0	q
	mm	mm	mm	mm	mm	mm	mm	mm	kN/lbf	kN	kg/m
420 OR	12.700	7.77	6.25	3.96	16.65	17.95	12.00	1.50	16.0/3599	17.00	0.62
420H OR	12.700	7.77	6.25	3.96	18.80	20.10	12.00	2.03	16.0/3599	17.00	0.74
428HVS	12.700	8.51	7.94	4.45	21.70	22.70	12.30	2.03	22.0/4946	23.00	0.85
50LD	15.875	10.16	9.53	5.08	23.40	24.60	15.09	2.03	22.2/5045	26.50	1.12
520 OR	15.875	10.16	6.70	5.30	21.20	22.30	15.09	2.20	32.0/7200	34.00	1.11
520F1 OR	15.875	10.16	6.25	5.30	21.20	22.30	15.09	2.20	32.0/7200	34.00	1.09
520F2 OR	15.875	10.16	9.65	5.30	24.10	25.50	15.09	2.20	32.0/7200	34.00	1.21
520V6	15.875	10.16	6.25	5.08	19.80	21.30	15.09	2.03	22.2/5045	26.50	0.96
520H OR	15.875	10.16	6.25	5.24	21.52	22.92	15.09	2.42	26.5/6022	29.60	1.26
525 OR	15.875	10.16	7.95	5.30	21.50	22.90	15.09	2.03	26.5/6022	29.60	1.30
525F1 OR	15.875	10.16	7.95	5.30	23.10	24.00	15.09	2.20	32.0/7200	34.00	1.16
520F14 OR	15.875	10.20	6.25	5.09	19.90	-	14.90	1.80	28.4/6391	30.60	0.92
525H OR	15.875	10.16	7.95	5.30	23.10	24.50	15.09	2.42	26.5/6022	29.60	1.44
530H OR	15.875	10.16	9.53	5.24	24.80	26.20	15.09	2.42	29.0/6524	30.00	1.39
630F1 OR	19.050	11.91	9.53	5.94	25.50	27.30	18.00	2.42	31.8/7149	35.00	1.50

X形密封圈摩托车链 X-Ring motorcycle chains

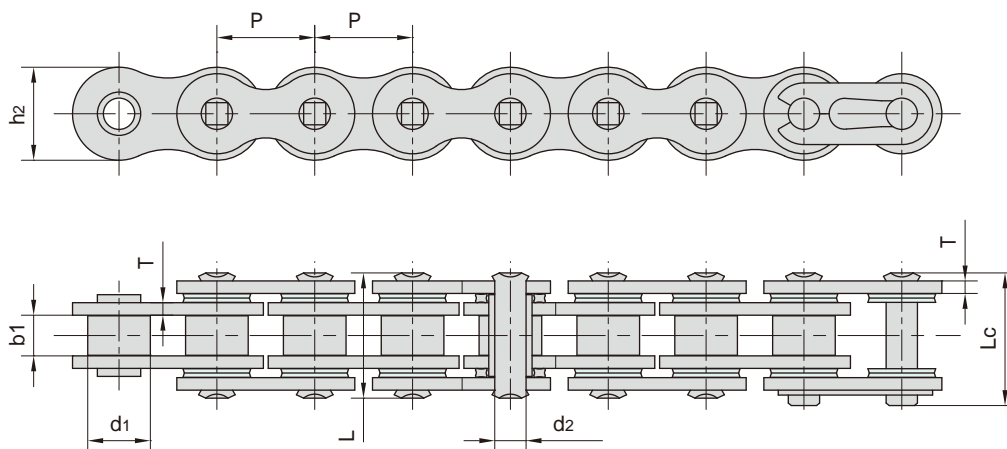

东华链号 Donghua Chain No.	节距 Pitch	滚子直径 Roller diameter	内节内宽 Width between inner plates	销轴直径 Pin diameter	销轴长度 Pin length		内链板高度 Inner plate depth	链板厚度 Plate thickness	抗拉强度 Tensile strength	平均抗拉强度 Average tensile strength	每米长重 Weight per meter
	P	d1 max	b1 min	d2 max	L max	Lc max	h2 max	T max	Q min	Q0	q
	mm	mm	mm	mm	mm	mm	mm	mm	kN/lbf	kN	kg/m
520 XR	15.875	10.20	6.25	5.09	20.10	21.10	15.09	2.03	28.00/6294	29.4	1.00
520F9 XR	15.875	10.30	6.25	5.39	20.10	-	15.00	2.03	33.83/7605	35.5	1.00
520H XR	15.875	10.16	6.25	5.24	21.52	22.92	15.09	2.42	30.00/6744	31.5	1.28
525 XR	15.875	10.20	7.85	5.09	21.70	22.70	15.09	2.03	26.50/5957	27.8	1.07
525H XR	15.875	10.16	7.95	5.30	23.10	24.50	15.09	2.42	26.50/5957	27.8	1.44
525SH XR	15.875	10.30	7.85	5.39	23.26	-	15.00	2.42	38.25/8599	40.2	1.20
530H XR	15.875	10.16	9.53	5.24	24.80	26.20	15.09	2.42	29.00/6519	30.5	1.39
530SH XR	15.875	10.30	9.40	5.39	24.91	-	15.00	2.42	38.25/8599	40.2	1.27